



ST850

AUTOMATIC TURKEY DEBONING MACHINE

MODEL



DESCRIPTION

All-round automatic turkey deboner suitable for male, female, left, right, anatomically cut thigh, drum and prime wing. Please check our website and product matrix on the main folder for more information. When ordering, please provide STEEN with the electrical specifications. Also inform us with the min./max. length and weight of each part including the required capacity in pieces per minute. Please also inform if your product is water or air chilled and the time span between killing and deboning. Optimal results occur between 2 and 4°C. In case of special requirements regarding the product, don't hesitate to ask our advice.

Полностью автоматический дебонер частей индейки. Предназначен для обработки частей индейки как самцов так и самок, левых и правых анатомически отрезанных бедер, голени, плеча. Для получения дополнительной информации, пожалуйста, посетите наш сайт и проверьте таблицу с применяемыми продуктами. При заказе, пожалуйста, предоставьте STEEN информацию по требуемому электрическому подключению. Также сообщите нам минимальные и максимальные размеры каждой части и требуемую производительность. Пожалуйста, также сообщите нам, если ваш продукт охлажден водой или воздухом и промежуток времени между убоем и снятием кожи. Оптимальные результаты достигаются при температуре 2- 4°C. В случае особых требований относительно продукта, обратитесь к нам за консультацией.

全自动火鸡剔骨机适合于公鸡，母鸡，左腿，右腿，分割后的上腿，琵琶腿以及全翅，请查阅我们的网站和主文件册上的产品列表以了解更多信息。订购时，请告知STEEN您的电源规格，同时告知我们所加工产品的最小/最大长度和重量，以及每分钟的产量，同时请告知我们您的产品是水冷却还是气冷却，宰杀和剔骨之间的时间间隔。产品温度在2-4°C时，剔骨效果最好。如果您对产品有特殊要求，请随时咨询我们的意见。

TECHNICAL DATA

FEATURE	DATA
Operators	1
Voltage range (1)	220- 575V 50-60Hz
Power (1)	2,23kW/3 phase
Controls	24V
LxWxH (2)	800x1620x2350 mm
Weight (3)	832 kg
Working width (2)	-
Water usage (4)	0,5l/min
Water connection	1/4"
Air usage	1,4m ³ /min. at 8 bar
Air connection	1/2"
Speed (5)	Variable: up to 35 pcs. per minute

(1) depending on requested voltage

(2) 1mm = 0,03937 inches

(3) 1kg = 2,20462 pounds

(4) 1l = 0.264172052 US gallons

(5) 50 CFM at 116 psi



FOOTPRINT

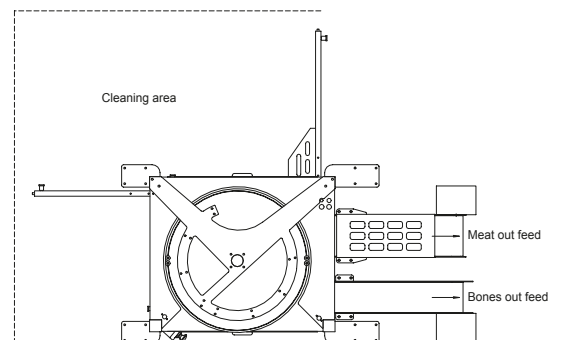
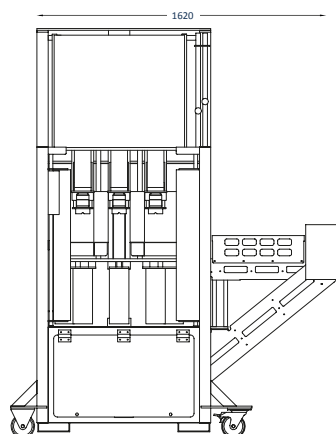
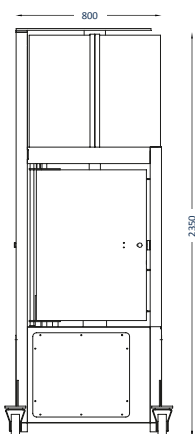

Due to the high degree of customization possibilities, technical data of the final product may vary.



OPTIONS



ST850

AUTOMATIC TURKEY DEBONING MACHINE

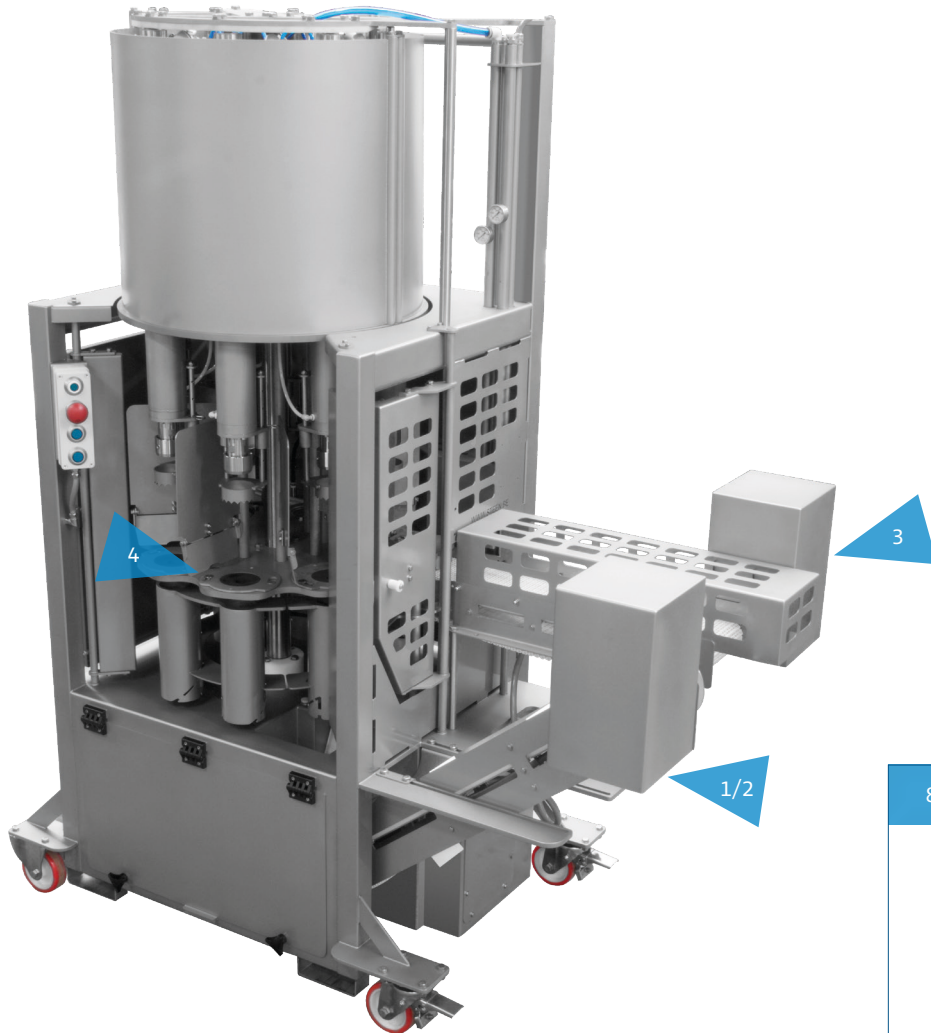

850/HIGH BONES 1

High outfeed belt- Bones

850/SHORT BONES 2

Short outfeed belt- Bones

850/LONG MEAT 3

Long outfeed belt – Meat

DIAPHRAGM 4

Diaphragms in various sizes

850/LEFT

Machine mirrored

CUSTOMIZED 5

Tailor-made solution

Due to the high degree of customization possibilities, technical data of the final product may vary.